



# AlphaTracer Industry

Serial 12 Volt & PWM (0 – 10 V)

## Real-time radon measurements in humid rooms

The AlphaTracer is a professional, highly innovative real-time radon sensor for fixed installation in smart buildings for connection to ventilation controls or other devices suitable for analog or digital input signals. It measures Rn-222 activity concentration in indoor air, which is provided as a proportional digital or analog output signal.

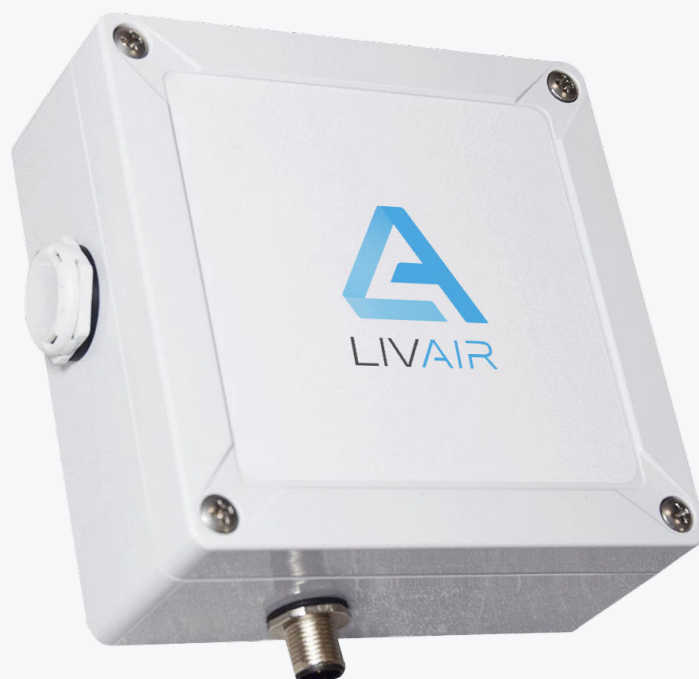

# Sensor Specifications

Technology	Lucas Cell
Initial measurement value	10 min
Data interval	10 min
Sensitivity	17 cph at 100 Bq/m <sup>3</sup>
Operation conditions	0 – 60 °C , RH < 99 %
Digital range	0 – 1,000,000 Bq/m <sup>3</sup> (0.2 – 27,000 pCi/l)
Analog range	0 – 20,000 Bq/m <sup>3</sup>
Precision	< ± 10 % at 370 Bq/m <sup>3</sup> (10 pCi/l)
Accuracy	< ± 10 %
Data communication	UART   PWM 0 – 10 V
Diffusion time	~ 10 min

# General Device Specifications

## Dimensions, Weight and Placement

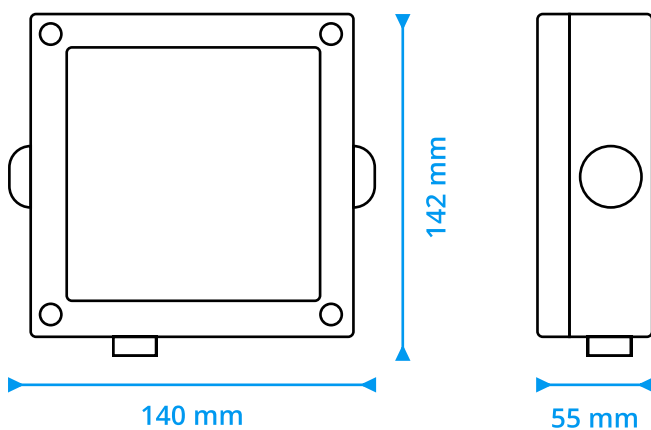

**Weight: 303 g**

The sensor can be mounted in any conceivable position, as it is not sensitive to humidity or vibration.

## Calibration

Recalibration is recommended every 3 years. If the sensor is exposed to very high concentrations (on average more than 1,000 Bq/m<sup>3</sup>), calibration is recommended every 2 years. A factory calibration is offered by the company LivAir GmbH. The sensor itself does not require any maintenance.

# Safety and warning notices



Please read the data sheet carefully before commissioning the AlphaTracer. Damage caused by non-observance of the instructions in the data sheet is excluded from any liability.

- The radon sensor may only be installed by qualified personnel and must be installed in accordance with the data sheet.
- To avoid damage to the sensor, check that it has been connected correctly before applying the supply voltage.
- When unpacking, it must be checked whether the correct device version has been delivered.
- The AlphaTracer may only be used in the manner described in this operating manual. If the product is used in any other way, this may result in danger to the operator as well as destruction of the sensor.
- No technical modifications may be made to the sensor.
- The sensor housing should only be cleaned with a damp cloth. Do not use scouring agents or cleaning agents containing solvents.
- Furthermore, the sensor must not be used if the ambient conditions are not within the limits specified in the data sheet.
- The sensor must not be used in an explosive atmosphere.
- Failure to observe the safety instructions may result in damage to the sensor and injury to the user.

# Power and Connectivity Options

**Power** 12 V (11 – 24 V DC, 16 mA)

**Communication** M12 plug

An overvoltage protection is available, which triggers at > 26 V. The output frequency at PWM is 3.81kHz. The output resistance is 0.035 Ohm at the output via N-channel FET without an RC element.

There is a M12 connector to connect the sensor. As soon as the sensor is supplied with voltage, the measurement starts.



## Pin assignment

Number	Connection
1	PWM
2	Vcc
3	GND
4	RXD
5	TXD

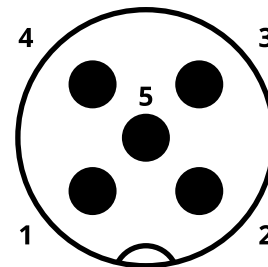

Pin assignment M12 male connector, 5-pos.,  
A-coded, male side

You can use a cable like the **AA044Sensor cable 5m PUR M12 5-pole**

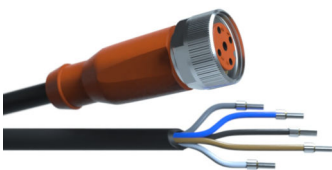

# Analog output and test signal

In addition to the serial digital output, the sensor also has an analog output. There are various operating settings for this analog output. Furthermore, the minimum and maximum radon value for the analog output can also be set.

There is a test signal as soon as the sensor is supplied with voltage. In the first minute, 100 Bq/m<sup>3</sup> is indicated on the digital output. The analog output behaves according to its configuration.

## For example

Max Radon value for 100 % = 1,000 Bq/m<sup>3</sup> and Min Radon value for 0 % = 0 Bq/m<sup>3</sup> then 0.5 V is output at the analog interface within the first minute (because of the indicated 100 Bq/m<sup>3</sup>).

The analog output settings can be set to a minimum and maximum value. Between these two values, the analog output regulates. The general volt range is 0.01 V.

There is an analog resistor which protects the circuit from damage if a short circuit is happening (250 Ohm).

There are seven different PWM output signals possible, to change the analog settings please use our AlphaTracer sensor tool. You can download it from our website. With this tool you can read out the sensor live values, set the minimum and maximum radon value and select the PWM mode.

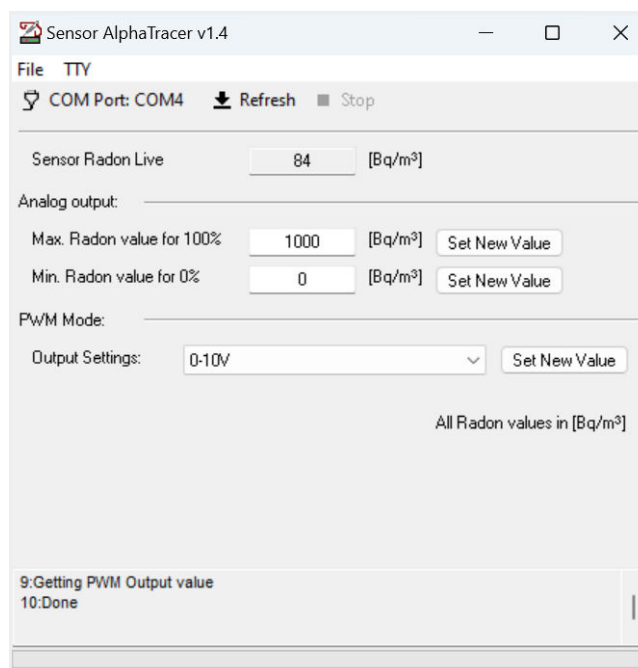

## PWM Mode - Output Settings

There are several PWM modes available. The 0 – 10 V, 2 – 10 V and the 1 – 10 V mode just work in the 0 – 10 V sensor version.

### 0 – 10 V

The standard PWM output setting is the 0 – 10 V output (in our example 0 V = 0 Bq/m<sup>3</sup> and 10 V = 1,000 Bq/m<sup>3</sup>, you can change these values as you like) in between there is a linear distribution.

## 5 % to 95 %

It's a 5 % to 95 % PWM output. This means that the sensor always outputs at least 5 % and maximum 95 % of 10 V within the defined max and min Radon values in %. As soon as the sensor is supplied with voltage, the measurement starts and a test program runs.

First the test program starts, 100 Bq/m<sup>3</sup> is implied at the digital output for one minute. If the Max Radon value = 1,000 Bq/m<sup>3</sup> and the Minimum Radon value = 0 Bq/m<sup>3</sup> this means an output signal of about 1.4 V in the first two minutes. From minute 2 to minute 2.40 the test signal goes to 95 % percent ~9.5 V. From minute 2.40 to minute 3.25 the test signal goes to 97.5 % which corresponds to ~9.75 Volt. From minute 3.30 to minute 4.30 the test signal goes to 2.5 % and ~0.25 V.

From minute 4.30 the test signal ends and the normal PWM mode starts to work. This means that at least 5 % voltage (i.e. 0.5 V) is now present at the output. Since the sensor determines the first radon value after 10 minutes, this 0.5 V remains in any case until the 10 minute.

If the Radon value exceeds the Maximum Radon value, then the PWM output will be 97.5 %.

### For example

Radon Value Max = 1,000 Bq/m<sup>3</sup>. When the live Radon value reaches 1,000 Bq/m<sup>3</sup> then the PWM output is 95 % = 9.5 V. If the live Radon value now rises to 1,001 Bq/m<sup>3</sup> or higher the output will be 97.5 % (~9.75 V) as long as the live radon value is higher than 1,000 Bq/m<sup>3</sup>.

However, this maximum value applies only to the analog output and is intended to signal that a value higher than the Max Radon value is present. The sensor provides digital values up to 1,000,000 Bq/m<sup>3</sup> and analogue values up to 20,000 Bq/m<sup>3</sup>.

## 0/1 Trigger

In trigger mode, a maximum analog signal (10 V) is triggered for 0.5 seconds every 5 minutes, but only if the Max Radon Value for 100 % is exceeded. This can be used, for example, to operate a switchable socket with time relay for automatic resetting. As soon as the sensor is supplied with power, the measurement starts and a short test signal is sent. 8 seconds after the sensor is supplied with voltage, 10 V is output at the PWM output for 8 seconds. Then again 8 seconds 0 V and then again 8 seconds 10 V, so the test signal ends. After 10 minutes the sensor outputs the first Radon live value.

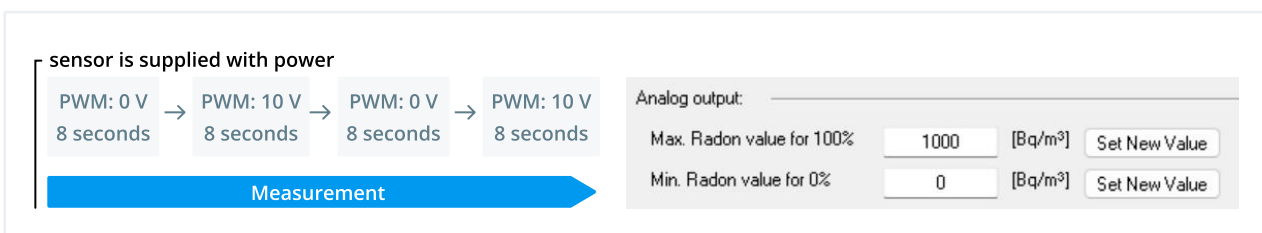

Graphical visualization of the test signal

## 0/1 Switch

In switch mode the analog output signal is 0 V until the max radon value is exceeded. As soon as this is exceeded, the output goes directly to 10 V until the value falls below the maximum radon value again (in our example 1,000 Bq/m<sup>3</sup>). This mode uses the same test signal as **0/1 Trigger** mode.

## Off

The PWM output is deactivated.

# Digital serial output

Serial communication, baud rate 19200

Communication kind	Get Live Radon value
Request message	"G08\$"
Respond message	"G08#00000000\$"
Range	[0,1000000]
Meaning	Bq/m <sup>3</sup>
Sensor poll interval	10 min

Example for the radon live values in Bq/m<sup>3</sup> (Value is updated every 10 minutes)

For this example the Radon value is 84 Bq/m<sup>3</sup>. Please do not poll the sensor more often than every 10 minutes.

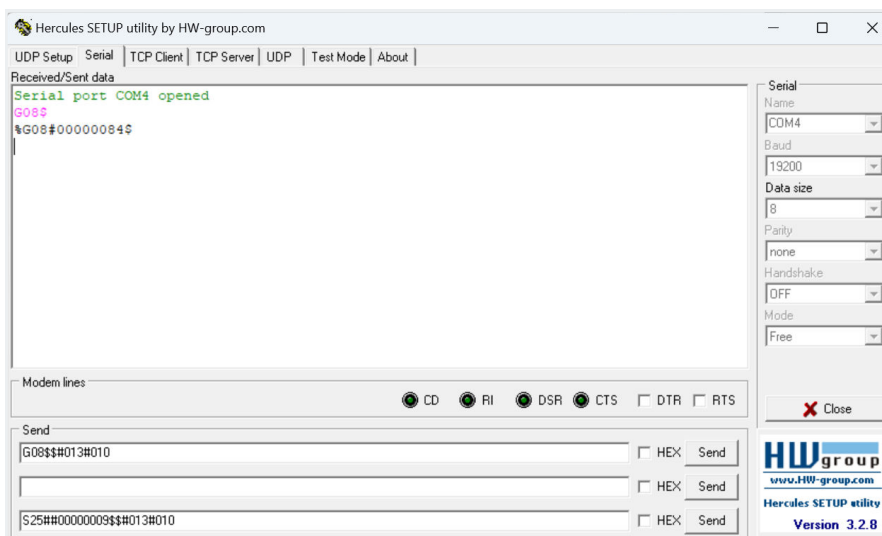

Example for an unix machine (with an usb to serial adapter)

The first requested radon value was 0 Bq/m<sup>3</sup> the second one 10 minutes later was 432 Bq/m<sup>3</sup>.

```
user@pc:~$ cu -l /dev/ttyUSB0 -s 19200
Connected.
%G08#00000000$
%G08#00000432$
```

# Comparative measurement

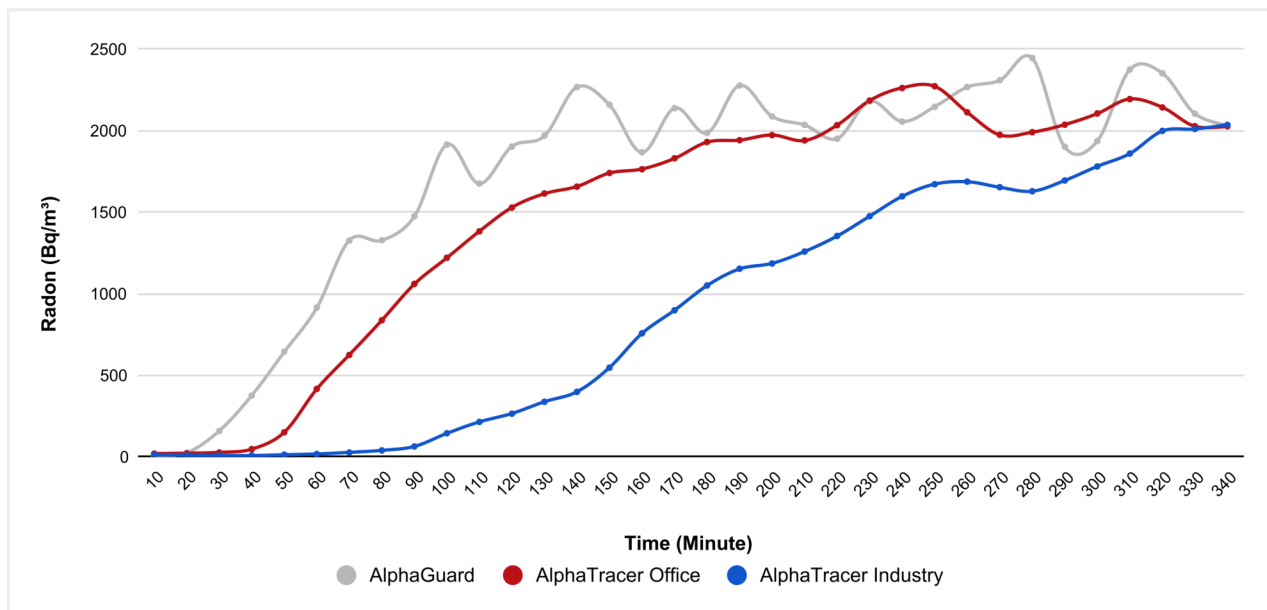

In this example, we have induced (under laboratory conditions) a very rapid increase in the Radon-222 activity concentration from 30 to over 2,500 Bq/m<sup>3</sup>:

Both AlphaTracer variants show, only delayed in time, the same total exposure as the reference instrument AlphaGuard (approx. 15,000 Euro acquisition cost).

Thus, the **AlphaTracer Office** reaches the measurement curve of the reference instrument with a time delay of approx. 30 min, the **AlphaTracer Industry** with a delay of approx. 100 min due to its IP54 class.

A very fast increase or decrease of the radon concentration leads to a delayed reproduction of the concentration change for radon measuring instruments with a denser housing and consequently slower air entry, but the correct measurement of the total exposure is not falsified or impaired by this.





## Get in contact with us!



[www.livair.io](http://www.livair.io)



[info@livair.io](mailto:info@livair.io)



LivAir GmbH • Agnes-Pockels-Bogen 1 • 80992 München